



*Brownie* **SYSTEMS**

A Unit of **GLOBAL** Industries, Inc.

# T6 Two Column Tower

CONSTRUCTION AND OWNER'S MANUAL

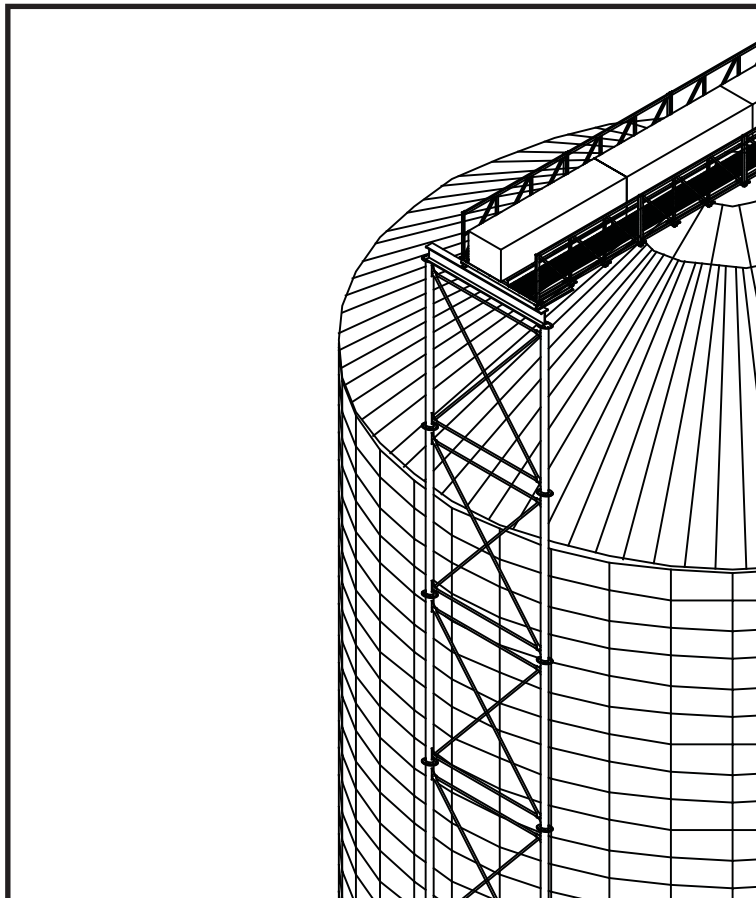



The Symbol shown below is used to call your attention to instructions concerning your personal safety. Watch this symbol - it points out important safety precautions. It means “ATTENTION” - Become Alert! Your Personal Safety Is Involved! Read the message that follows and be alert to the possibility of personal injury or death.



**Be Alert!**

**Your Personal Safety Is Involved**

A copy of this manual should be available at all times to the owner/operator. Additional copies may be requested from the company at the address shown on the back cover. Please reference manual part number 4000021 when requesting additional copies.

Please Contact BROWNIE SYSTEMS or Your Dealer  
If You Have Any Questions Concerning This Manual

**Keep This Manual In A Safe Place Available For Future Reference**



## PREFACE

You have purchased the finest Two Column Tower manufactured today. The following information is intended as a guide in caring for your tower before construction, proper construction of your tower, and safe and proper use of your tower after construction.



## General Safety Statement

Your safety and the safety of others associated with this tower is of prime concern to us at Brownie Systems. This manual was written with the safety of the operator and/or others who come into contact with the tower as our prime concern. We wrote this manual to help you to better understand how to safely build and use your tower.

It is your responsibility as the owner, builder, operator, or supervisor, to know what specific requirements, precautions, and hazards exist and to make these known to all personnel working with the equipment or in the area, so that they too may take any necessary safety precautions that may be required!

Failure to read this Manual and its Safety Instructions by all personnel is a misuse of the equipment. We want you as our partner in safety!

All personnel, including construction personnel, must read and understand all equipment Operator's Manuals before starting tower construction!

# Contents

Be Alert.....	2
General Safety Statement.....	3
Warranty.....	6
<b>1</b> Safety.....	7
<b>2</b> Introduction.....	11
Bolt Torque.....	12
Parts.....	13
<b>3</b> Foundation.....	14
<b>4</b> Assembly.....	17
Tower Sections.....	17
Installation Requirements.....	18
Index.....	22

**Notes:**



# Warranty

**Global Industries Inc.** (the **Company**) makes the following warranty to the initial retail purchaser of its products (the **Customer**).

## **MATERIALS and WORKMANSHIP:**

The Company warrants products manufactured by it to be free from defects in materials and workmanship in normal use and service for a period of one (1) year after date of delivery to the Customer.

## **COMPANY'S OBLIGATION and CUSTOMER'S EXCLUSIVE REMEDY:**

The Company's sole obligation and the Customer's exclusive remedy under this warranty is as follows:

If within one (1) year after delivery to the customer the product fails to function properly due to a defect in either materials or workmanship, the Company will at its option, either repair the defective part or replace the defective part with a new or reconditioned part. Labor charges for removing defective parts and installing replacement parts, shipping charges with respect to such parts, and applicable sales and other taxes, if any, shall not be covered by this warranty.

## **CONDITIONS, LIMITATIONS, AND EXCLUSIONS:**

**There are no warranties or merchantability or fitness for a particular purpose** with respect to any product manufactured or sold by the Company. Motors provided by the Company are in most instances warranted by the manufacturer thereof and are not warranted by the Company. The Company shall not be responsible under this warranty or otherwise for personal injury or for **Incidental or Consequential Damages**, including, without limitation, loss of use and lost profits. This warranty does not apply to defects or damages caused by misuse, improper maintenance, or improper installation of the Company's product or any equipment attached to or used in connection with the Company's product. The Company reserves the right to make changes or improvements to its products without incurring any obligation with respect to previously manufactured products. Field modification of this product without the expressed written permission of the Company constitutes a misuse of the product. The Company shall have no liability under this warranty until payment in full for the product in question has been made by the customer. The foregoing is the sole warranty made by the Company. No one is authorized to make other warranties on behalf of the Company.

# 1

# Safety

This Brownie Systems Construction and Owners Manual is written to assist and instruct those who are responsible for tower assembly, and for anyone using the tower once assembled.

Global Industries Inc. assumes no liability with respect to proper assembly, installation, and inspection, or use of its products established under applicable laws, all of which is the sole responsibility of the purchaser and those doing the assembly work.

Appurtenances and the accessories manufactured by us for use with our products conform only to applicable Federal or Safety Standards in effect at such time.

## GENERAL SAFETY STATEMENT

Occupational safety is of prime concern to us at Brownie Systems. This manual was written with the safety of the operator or others who come in contact with the equipment as our prime concern. We wrote this manual to help you to better understand how to safely build and use this tower.

It is your responsibility as an owner or operator or supervisor, to know what specific requirements, precautions, and work hazards exist and to make these known to all other personnel working with the equipment or in the area, so that they too may take any necessary safety precautions that may be required.

Failure to read this Manual and its Safety Instructions by all personnel is a misuse of the equipment. We want you as our partner in safety.



**WARNING! Watch For This Symbol:**  !

It Points Out Important Safety Precautions. It Means

“ATTENTION” - Become Alert! Your Safety Is Involved.



ALL INFORMATION ON THIS PAGE  
IS WARNING INFORMATION!

## WORK AREA SAFETY STATEMENT

Under no circumstances should persons not involved in the operation be allowed to **trespass** into or be present in the work area.

It shall be the duty of all operators to see that children and/or other persons stay out of the work area! Trespass into the work area by anyone not involved in the actual operations, or trespass into a hazard area by anyone, shall result in an immediate shut down by the operator.

It shall be the responsibility of all operators to see that the work area has secure footing and is clean and free of all debris and tools which might cause accidental tripping and/or falling. It shall also be their responsibility to keep the work area clean and orderly during the operation. It shall also be the responsibility of the operator to have damaged equipment repaired and to be made free of sharp edges.



## OSHA OCCUPATIONAL SAFETY AND HEALTH ACT OF 1970

Certain purchasers of our products may be subject to the requirements and standards of the William-Steiger Occupational Safety and Health Act of 1970, which prescribes standards for use of appurtenances of our manufacture, such as handrails, platforms, stairways, fixed ladders, ladder cages, and guard rails. (Occupational Safety and Health Standards Section 1910.21 through 1910.32). Before installing these devices, familiarize yourself with the above Federal Standards.

At the time of manufacture, these **optional** items conform to applicable standards. Global Industries Inc. assumes no liability with respect to proper construction, inspection, assembly, or use of its products under applicable laws, all of which is the sole responsibility of the purchaser and those doing the assembly work.

**A** When climbing or walking on towers, ladders, spanning structures, catwalks, or trusses, take care not to fall from these structures. Common sense dictates that such appurtenances should not be used when conditions such as rain or wind preclude their safe use. Brownie Systems strongly recommends that optional climbing equipment be purchased to meet the current specifications set forth by OSHA or ANSI whether the individual operator is required by law to do so or not. A properly secured safety belt should be used at all times when performing operations work or maintenance on Brownie tower.

**B** Field modification of this tower or any auxiliary components or equipment without the authorization of the manufacturer may present unknown dangers to the operator and must be avoided.

ALL INFORMATION ON THIS PAGE  
IS WARNING INFORMATION!



**WARNING!** Owners and Contractors: Before starting construction of your TC6 Two Column Tower, 1) READ AND UNDERSTAND THIS ENTIRE MANUAL! 2) Read and understand the instructions for all equipment, auxiliary equipment, structures, other products, and the like within or connected to this TC6 Two Column Tower. 3) View all illustrations in this manual. 4) Read and understand any applicable OSHA Regulations, Building Codes, and Electric Codes.



**WARNING!** Make certain that all persons on this THIS TOWER during construction are properly fastened to safety cables to prevent injury or death due to falling!



**WARNING!** Installation of accessories or equipment in or on THIS TOWER that would over stress the structure in any manner will void the Warranty. If you do not have specific recommendations from Brownie Systems, where additional loading is involved, please contact Brownie Systems before installing any such appurtenances or equipment.



**WARNING!** Make certain all persons within the work area on ladders, lifts, crane lifts, scaffolds, or the like are secure and not in danger of falling! And, make certain work surfaces are clean and free of clutter.



**WARNING!** Any alterations to this tower without the authorization of the Brownie Systems engineering department is prohibited!



**WARNING!** Local codes supersede the instructions provided in this manual and should be strictly adhered to. Contact the manufacturer if you have questions.



**WARNING!** Avoid injury or death! Use extreme caution when working from heights. Use the proper equipment when working from heights. Take the proper precautions to prevent persons or objects from falling!



**WARNING!** DO NOT substitute parts or hardware for those supplied by Global Industries, Inc.



ALL INFORMATION ON THIS PAGE  
IS WARNING INFORMATION!



**WARNING!** DO NOT use any damaged tower parts.  
It may not be safe!



**WARNING!** When adding additional equipment not previously accounted for, considerable wind load or weight may be added to the tower. Be certain that your Brownie Tower is designed and staged for all equipment, and any future additions. If you are uncertain, contact the factory before installing the tower.



**WARNING! IMPORTANT:** If any question or difficulty should arise during the process of Tower installation, the contractor or owner should contact Brownie Systems to get an answer or to resolve the problem!

ALL INFORMATION ON THIS PAGE  
IS WARNING INFORMATION!

# 2

## Introduction

The TC6 Two Column Tower is an efficient catwalk/conveyor support option, featuring a minimal surface area requirement. It is ideal for situations where space is limited. The two column tower is available in 5' [1524mm], 8' [2438mm], and 10' [3048mm] section heights, for 6' [1829mm] and 8' [2438mm] tower widths.

### PRE-INSTALLATION CHECKLIST

- 1 Tools:** The following tools are required for the TC6 assembly and installation.
  - 1 - 5/16" open-end wrench and/or socket
  - 15/16" open-end wrench and/or socket
  - 5/8" open-end wrench and/or socket
  - Torque wrench
- 2 Foundation:** The foundation is critical to the integrity of the TC6 tower. Consult an engineer for foundation design, to meet conditions unique to your site (soil type, water table, concrete quality, etc.). To assist with the foundation design, Brownie Systems will provide information relative to the tower reactions at foundation. **Note: This instruction manual provides foundation recommendations. This is general information, only. Consult a qualified engineer for your specific foundation needs.**
- 3 Wall attachment:** The TC6 tower is not a free-standing tower. The tower must be supported at various elevations, detailed in Installation Requirements of the construction manual. The end-user is responsible for fabricating the support attachments.
- 4 Support beam:** A support beam is required to transfer catwalk/conveyor loads into the TC6 support tower. The end-user is again responsible for fabricating the support beam. Minimum material requirements are listed in the table below.

**Support Beam Material Requirements**

Catwalk Type	TC6 Tower 6' [1,829mm] wide	TC6 Tower 8' [2,438mm] wide
RS64	W8x15	W8x18
6A	W8x15	W8x18
6B	W10x22	W10x30
6C	W12x26	W12x35
6D	W14x34	W14x48



# Bolt Torque

## TORQUE VALUES AND HARDWARE IDENTIFICATION

Bolt Description	Bolt Grade	Torque (ft - lbs)	Bolt Identification
7/16" - 14 hex bolt	Grade 2	32	
5/8" - 11 hex bolt	Grade 5	170	
7/8" - 9 carriage bolt	Grade 5	465	



**WARNING!** UNDER NO CIRCUMSTANCES SHALL ANY OTHER BOLT BE SUBSTITUTED FOR THOSE SUPPLIED BY MFS/YORK/STORMOR!

Contact the factory with any Tower or Tower component construction or assembly problems.

**Phone: 1-800-228-4285**

**Fax: 1-308-382-6954**

# Parts

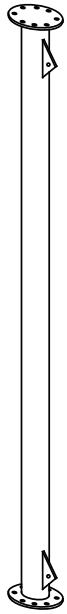

Tower Column  
(6-5/8" outside diameter)  
[168mm]

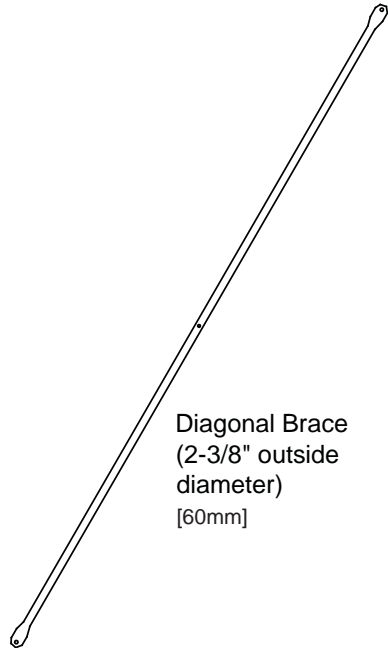

Diagonal Brace  
(2-3/8" outside diameter)  
[60mm]

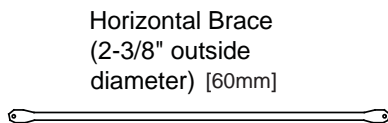

Horizontal Brace  
(2-3/8" outside diameter) [60mm]

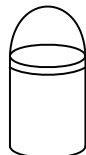

## TC6 (2) Column Tower Part Lists

		Part Number	Description	Quantity
<b>TC6 TOWER - 6' [1829mm] WIDE</b>	10' [3048mm] tall	-	Tower Column	2
		3988371	Horizontal - 63 3/8" [1610mm]	2
		3988370	Diagonal - 125 7/16" [3186mm]	2
		4800008	Hardware Package	1
	8' [2438mm] tall	-	Tower Column	2
		3988371	Horizontal - 63 3/8" [1610mm]	2
		3988373	Diagonal - 105 3/16" [3186mm]	2
		4800008	Hardware Package	1
	5' [1524mm] tall	-	Tower Column	2
		3988371	Horizontal - 63 3/8" [1610mm]	2
		3988376	Diagonal - 79 3/32" [2009mm]	2
		4800008	Hardware Package	1

<b>TC6 TOWER - 8' [1829mm] WIDE</b>	10' [3048mm] tall	-	Tower Column	2
		3989628	Horizontal - 88 3/8" [2245mm]	2
		3989622	Diagonal - 139 7/16" [3542mm]	2
		4800008	Hardware Package	1
	8' [2438mm] tall	-	Tower Column	2
		3986928	Horizontal - 88 3/8" [2245mm]	2
		3988428	Diagonal - 121 5/8" [3089mm]	2
		4800008	Hardware Package	1
	5' [1524mm] tall	-	Tower Column	2
		3989628	Horizontal - 88 3/8" [2245mm]	2
		3988425	Diagonal - 100 3/32" [2542mm]	2
		4800008	Hardware Package	1

<b>Hardware Package</b>	5/8" UNC x 2 1/2", grade 5 hex bolts	17
	5/8" lock washers	17
	5/8" hex nuts	2
	7/8" UNC x 2", grade 5	5
	7/8" lock washers	5
	7/8" hex nuts	5
	7/16" UNC x 5 1/2" grade 2 hex bolt	1
	7/16" lock washer	1
	7/16" hex nut	1

# 3

## Foundation

### Foundation (Example A)

Size:

19" x 89 5/8" [483mm x 2277mm]  
(6' [1830mm] wide tower)

Depth: Equal to depth requirement  
for bin wall footing.

**NOTE:** Example 4 illustrates  
extensions (19" x 19"  
[483mm x 483mm]) added to the bin  
foundation wall to accomodate the  
TC6 tower foundation.

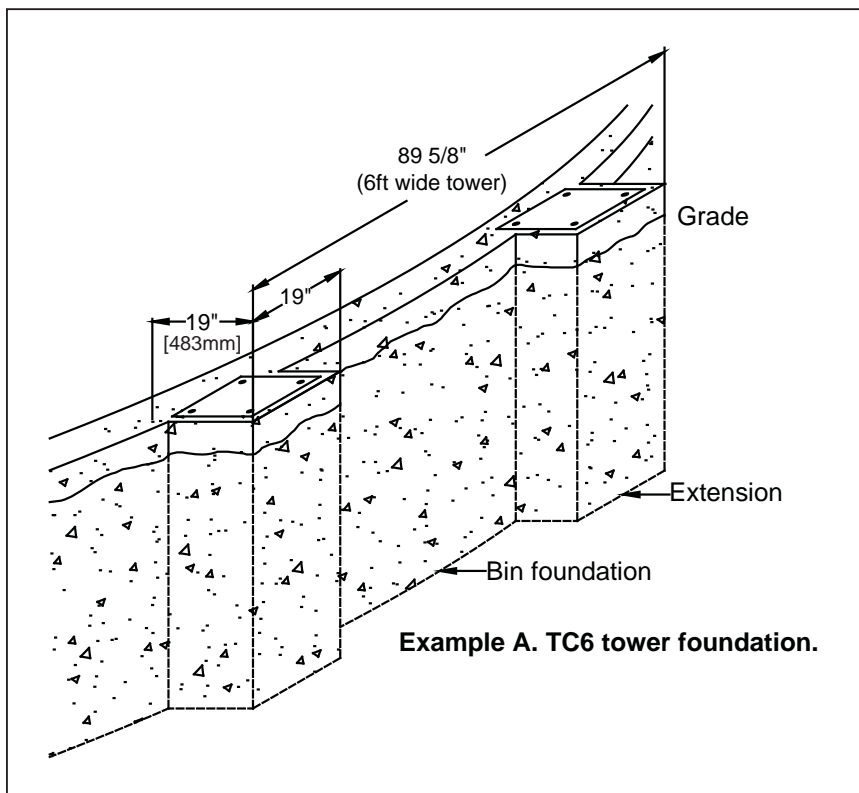

Foundation Anchor Rod (Example B)

Material:

3/4" [20mm] rebar

Length:

3/4 depth of foundation plus  
1' [305mm] from the end of each  
anchor rod.

Configuration:

Position anchor rods through holes  
in anchor plates, extending 1" [26mm]  
above plates. Apply a 5/8" [16mm]  
fillet weld all around.

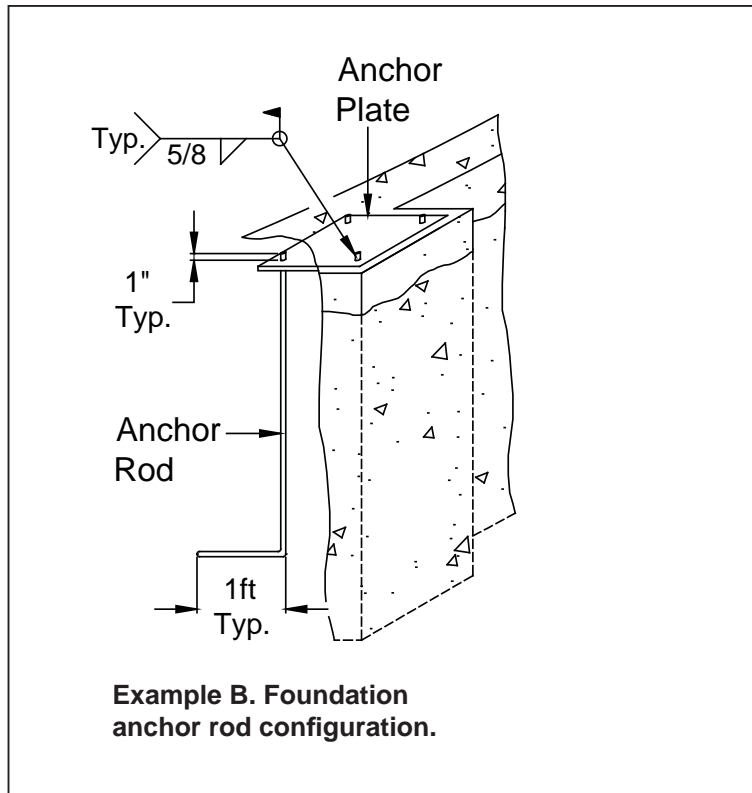



Anchor Plate (Example C)

Material: 5/8" [16mm] (A36) steel

Dimensions: 15" x 15"  
[381mm x 381mm]

Configuration: Position anchor plates with a minimum of 2" [52mm] concrete foundation all around, as shown in Example C.

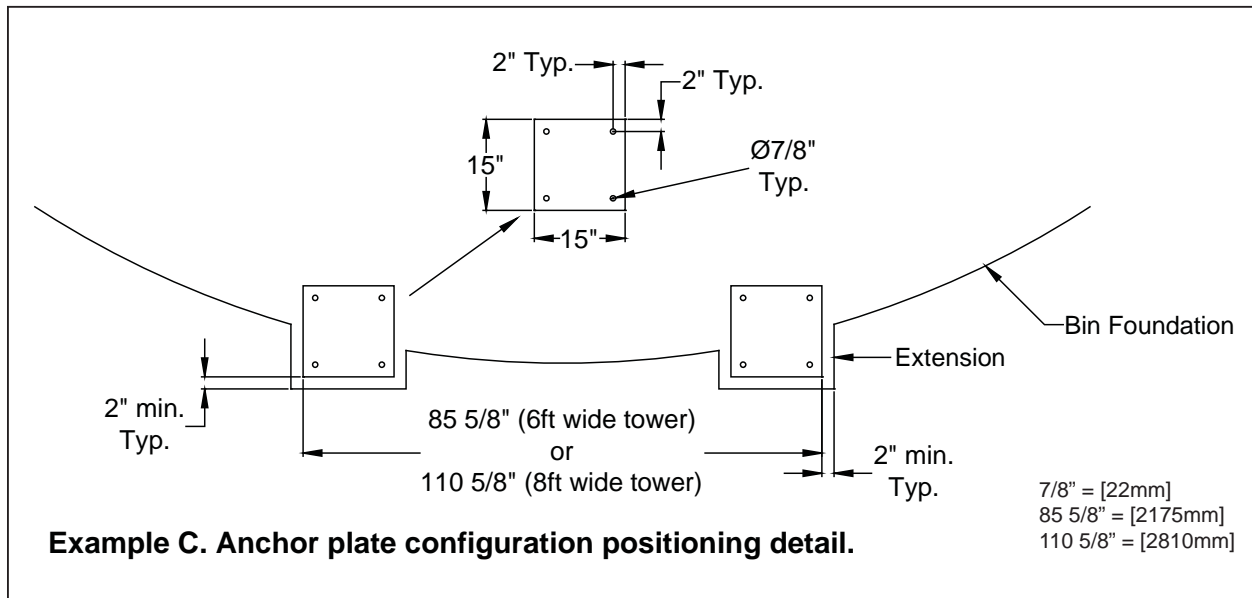

# 4

## Assembly

### Tower Sections

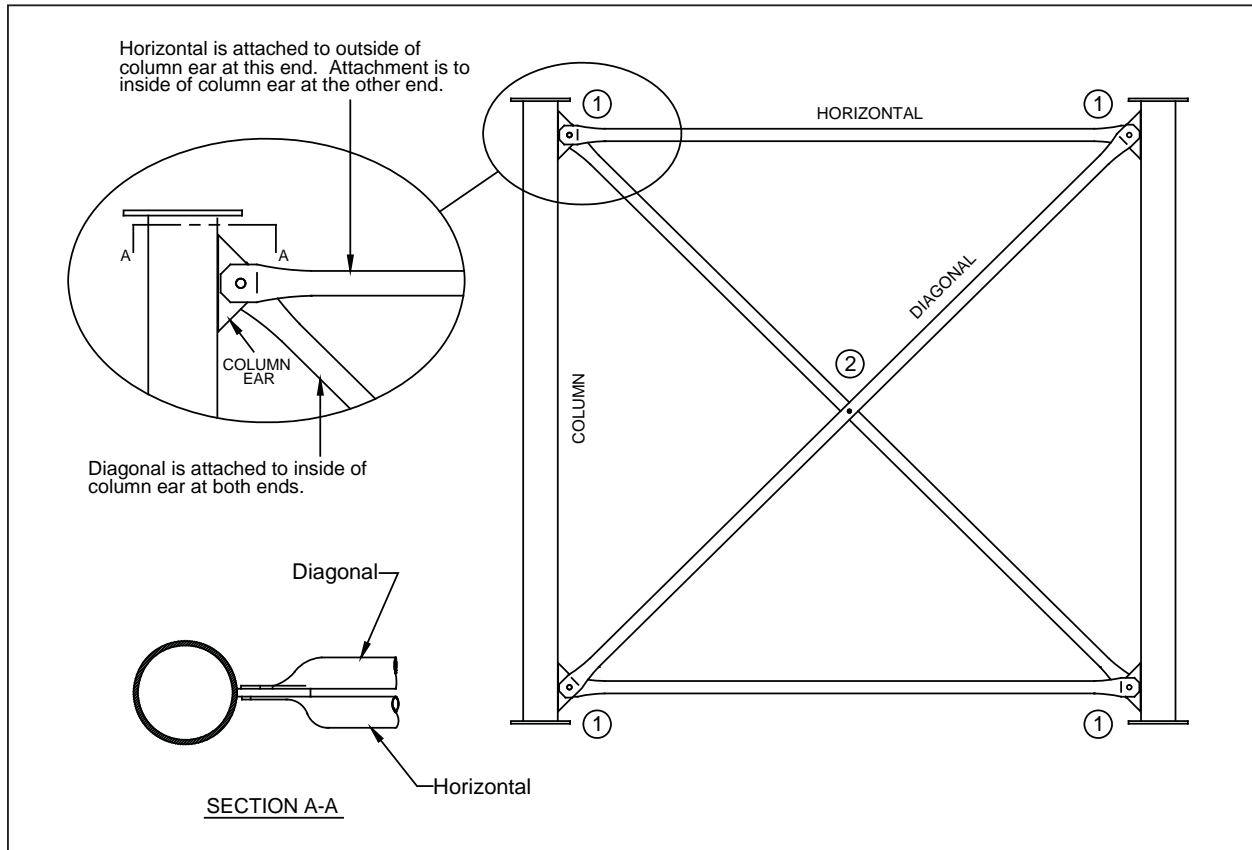

The tower section should be assembled on relatively level ground. All bolted connections should be finger-tight only at this time.

**1** Install (2) tower columns, (2) diagonals and (2) horizontals.

**2** Assemble diagonal and horizontal bracing to tower columns (LOCATION ①).

**Hardware:** 7/8" UNC x 2" grade 5 hex bolt, lock washer and nut.

Install diagonal braces to the same side of column ears; install horizontal braces to the opposite sides of column ears. Install bracing so that the column ear is "sandwiched" between the horizontal and diagonal brace. NEVER bolt bracing on the same side of column ear. See the example above. Note the position of bracing (section A-A); position the brace with flattened side of the brace next to the column ear (contact side).

**3** Connect diagonal braces (LOCATION ②).

**Hardware:** 7/16" UNC x 5 1/2" grade 2 hex bolt, lock washer and nut.



# Installation Requirements

See now the example on the [next page](#).

## 1 Install the base section (base section) of tower onto the foundation.

- Center the tower base section on the anchor plates.
- If necessary, shim between column plates and anchor plates to plumb and level the base section.
- Tighten hardware at all bracing connections, according to torque values table in this manual. Verify that the tower base section is plumb.
- Weld the tower columns to the anchor plates.

### *Welding Requirements:*

Apply a 1/2" [13mm] fillet weld around the column plate. Crown weld. Fill bolt holes in the column plates to prevent water seepage. Use E70xx or E80xx welding rod. **Attention: Certified welding personnel are required for all field welding requirements!**

## 2 Install the remaining sections.

Hardware: 5/8" NC x 2 1/2" grade 5 hex bolt, lockwasher and nut.

- Stack tower sections, until you reach an elevation, where wall attachment is required. See Bin Wall Connection on [the next page](#) for additional information.
- Tie the tower back to the support structure (i.e. grain bin).
- Tighten all hardware connections, according to the torque values provided in this manual.
- Repeat the above sequence, until the tower is completely installed.

If you are installing a galvanized tower, you must install tower top plates to each column splice at the very top of the tower! Use sealer caulking between the tower top plates and column splices as required. These are found with your hardware kit, and will install using column splice bolts, lock washers, and nuts. Performance of this step will prevent serious damage caused by freezing water!

### Bin Wall Connection

The TC6 (2) column tower must be supported at the following locations:

- ① Bin eave.
- ② Column splice below bin eave.
- ③ Every 30' [9144mm] below bin eave column splice.

Bin wall connections must be positioned within 7" [178mm] of column splices; an exception is at the bin eave.

Connections between the bin and tower are acceptable at any point along tower columns. Each column must be tied into an adequate support structure (i.e. grain bin) at the stated elevations. See pages 20 and 21 for suggested installation/connection methods.

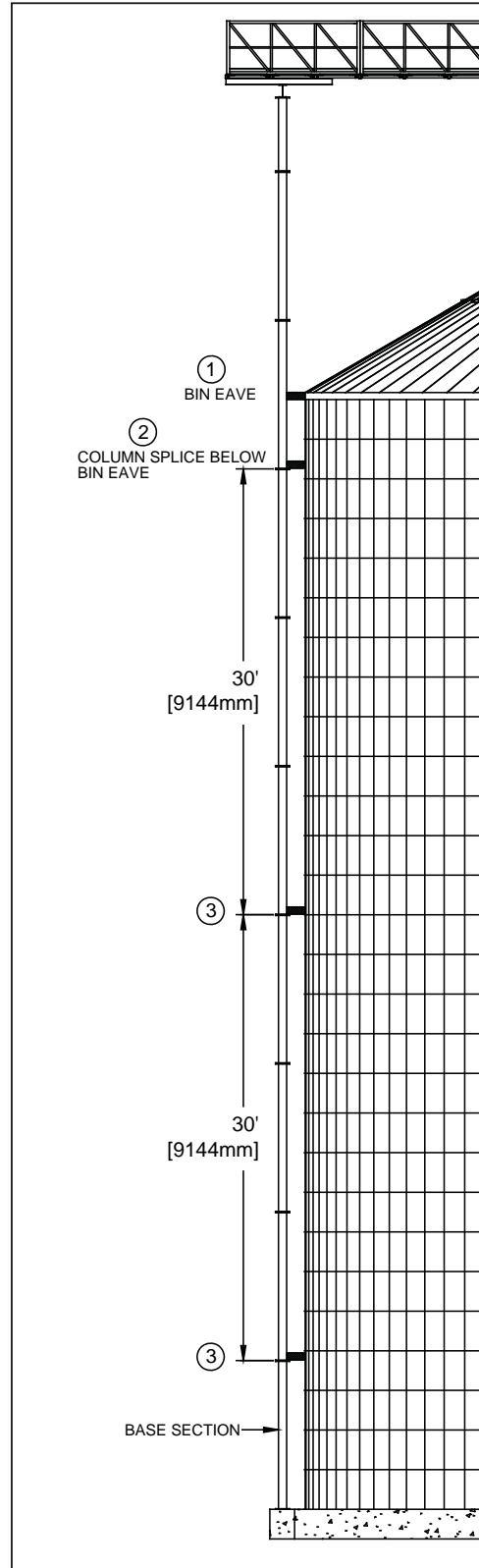



### 4 Assembly

There are (3) basic methods for connecting the (2) column tower to the bin sidewall, as shown in the examples on [this page](#) and [the next page](#). **Example 1** illustrates the connection method used when provisions have been made for the (2) column tower to anchor to the stem wall (foundation) of your bin. **Example 2** illustrates the connection method used when the foundation for the tower is independent of the bin foundation. **Example 3 and 3a** illustrate the connection method used when attaching to an inside stiffened bin.

#### Wall Connection Method (Example 1)

- Using 4" x 4" x 1/4" angle [102mm x 102mm x 7mm] (not supplied), drill (4) 11/16" diameter holes relative to the bolting locations on the column splice plates.
- Cut relief on the angle to avoid interference with the column weld at both locations.
- Install using existing hardware in the column splice plates.
- Use 1/2" (A36) plate. Fabricate standoffs to the configuration shown to fit your situation.
- Apply a 1/4" [7mm] fillet all-around weld, weld 2" x 2" x 3/8" [52mm x 52mm x 10mm] angle (18" [458mm] long or 4 ribs, whichever is greater) to the standoffs as shown. Make certain the angle is positioned so as to fit flush with the base of the stiffener.
- Drill and install the angle to the stiffener at the locations used for installing the stiffener.
- Apply a 1/4" [7mm] fillet weld around the contact area of the standoff and 4" [102mm] angle.

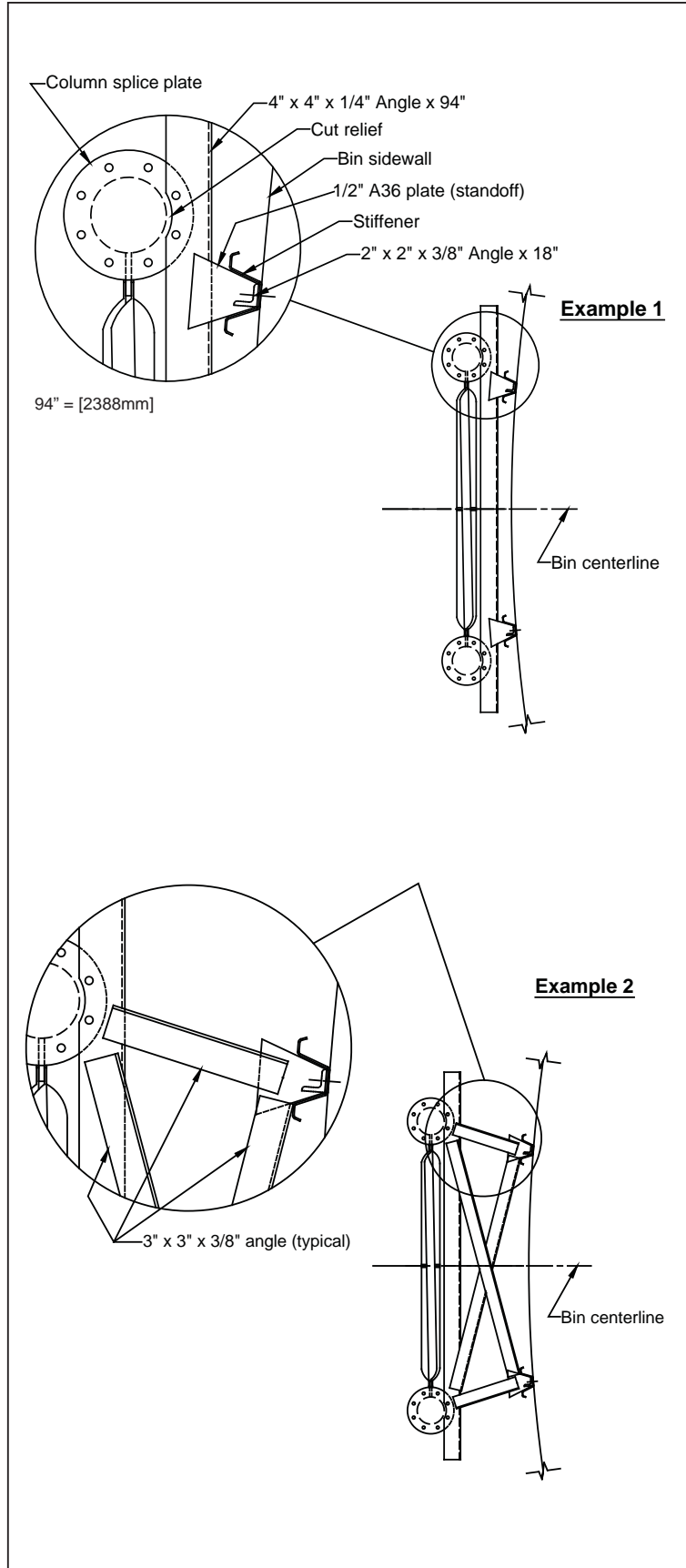

Wall Attachment Method (Example 2)

- Use the same guidelines in example 1. Install the 4" [102mm] angle to the column splice plates.
- Repeat the guidelines in example 1 for fabricating and installing the standoffs to the stiffeners.
- Use 3" x 3" x 3/8" [78mm x 78mm x 10mm] angle for the bracing members, cut and configure the layout for the bracing as shown in example 2.
- Apply a 1/4" [7mm] fillet all-around weld to all bracing connections at standoff and 4" [102mm] angle locations.

Wall Attachment Method (Example 3 and 3a)

- Follow the same installation guidelines as stated in examples 1 and 2 for installation under these conditions.

---

**NOTE:** For unstiffened bins use 3" [78mm] channel at least 4' [1220mm] long to simulate stiffeners at the connection location.

---

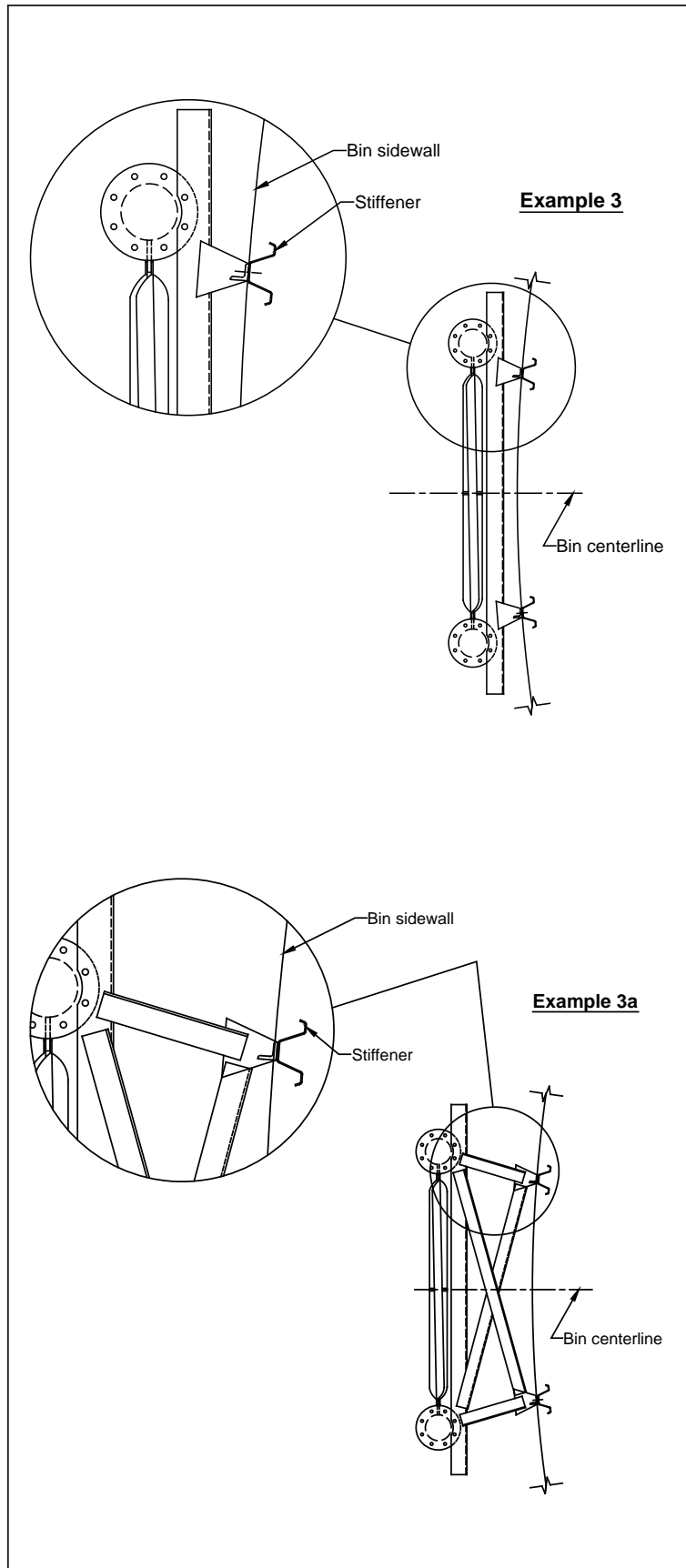

# Index

## A

accessories 9  
additional loading 9  
anchor plates 15, 16, 18  
assembly 17, 18, 19, 20  
auxiliary equipment 8

## B

base section 18  
be alert 2  
bin eave 19  
bin foundation 20  
bin wall connection 19, 20  
bolt torque 12  
bracing 17  
building codes 8

## C

caulking 18  
climbing equipment 8  
codes 8, 9  
column ear 17  
columns 13, 17  
column splice plates 21  
column splices 18, 19  
contents 4  
crane lifts 9

## D

damaged tower parts 10  
diagonals 13, 17

## E

electric codes 8

## F

fixed ladders 8  
foundation 14, 15, 16, 20  
foundation anchor rod 15  
freezing water 18

## G

general safety statement 3, 7  
guard rails 8

## H

handrails 8  
hardware 13, 17, 18, 20  
hazards 3, 7  
horizontals 13, 17

## I

inside stiffened bin 20  
installation requirements 18  
introduction 12

## L

ladder cages 8  
ladders 9  
lifts 9

## O

occupational safety and health act of 1970 8

operation 7

OSHA 8

## **P**

parts list 13

platforms 8

precautions 3, 7

preface 3

## **S**

safety 2, 3, 7, 8, 9, 10

safety cables 9

scaffolds 9

shims 18

stairways 8

standoffs 20, 21

stem wall 20

stiffeners 20, 21

support structure 19

## **T**

TC6 (2) column tower parts list 13

torque values and hardware identification 12

tower sections 17, 18

tower top plates 18

## **U**

unstiffened bins 21

## **W**

wall attachment method example 1 20

wall attachment method example 2 21

warranty 6

welding 15, 18, 20, 21

welding rod 18

wind/weather 8

wind load 10

work area 7



# Notes:

## Recent Significant Manual Changes:

### 7-08 [1] Version Changes

- 1** Metric dimensions were added throughout the manual.
- 2** Additional safety information was added to the manual.
- 3** An index was added.
- 4** Other minor changes were made throughout the manual.



GLOBAL INDUSTRIES, INC.

for information on other Global Industries products see: — [www.globalindinc.com](http://www.globalindinc.com) —

for information on other Brownie Systems products see: — [www.go-brownie.com](http://www.go-brownie.com) —

## **BROWNIE SYSTEMS**

P. O. Box 2105 • Grand Island, Nebraska 68802 - 2105, U.S.A.

**(800) 228 - 4285 • FAX (308) 382-6954**

© 2008 Global Industries, Inc. All rights reserved.